

EAM BOMBER 17 FUSE INSTRUCTIONS

While the wing is drying and BEFORE you install the cap rib on the wing, cut out the pre defined holes in the fuse. Cut the fuse holes, the front hole is not critical that you match the size just yet, but the other two are important. You can cut it close and then file it out with a rat tail file or a round file.



Insert a 1 " tube (or the phenolic sleeve of a 7/8" wing tube) and the 7mm carbon fiber tube supplied. Slide the cap rib over and mark the holes that need to be cut into the fuse. Cut the fuse holes, the front hole it is not critical to match the size just yet, but the other two are important. You can cut it close and then file it out with a rat tale file or a round file.



Once the holes are cut out, they should look like this.



Inside view.

EAM BOMBER 17 FUSE INSTRUCTIONS



Early versions of the inside supports were not cut for all the holes. It will be necessary to mark and cut them out. Line them up with the wing cap rib and mark. Cut to the inside of the line and increase the size as necessary to match either a 1" aluminum wing tube or a phenolic sleeve from a 7/8" wing tube.

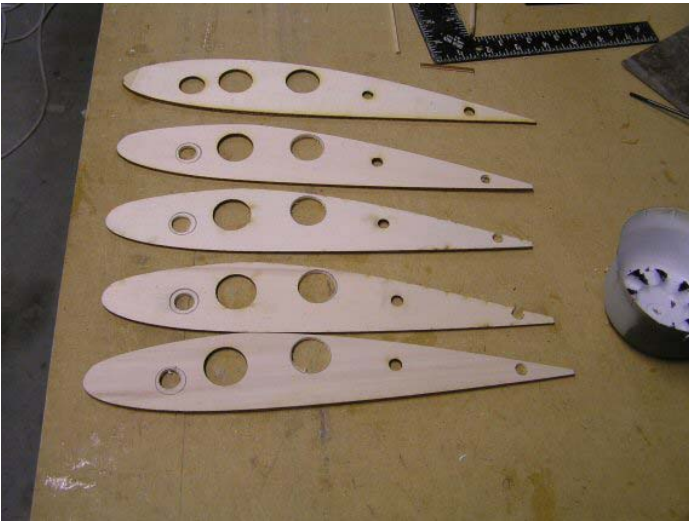

Cut outs should look like this. If the inside supports already have the holes, then this step is not necessary.



Next place the inside supports against the fuse as pictured. As cut they will not fit flush against the fuse, trimming will be required.

EAM BOMBER 17 FUSE INSTRUCTIONS



You can see here that the brace is not flush with the fuse. Trim away as necessary to get the brace flat against the inside of the fuse. Repeat for both sides.

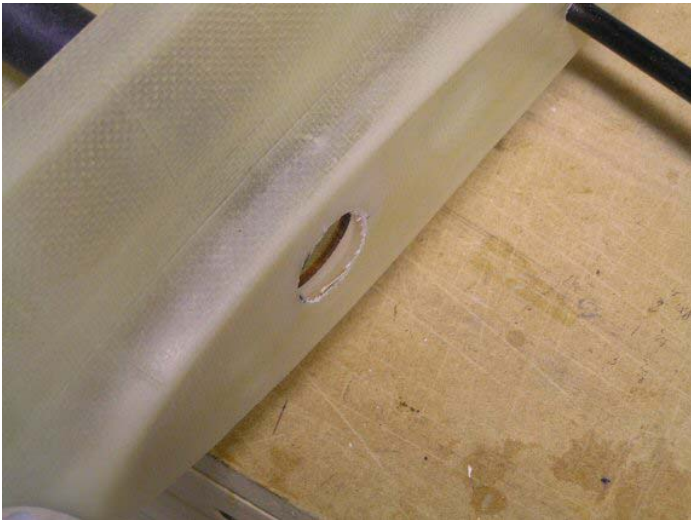

This shows how far the brace might be from being flush.



Once the braces are flush, cut the phenolic tube off with about ¼" protruding from each side, be careful and don't cut it off to short. Put some Vasaline on the metal tube, or extra phenolic tube and the 7mm carbon tube. Put glue (Poly Urethane or Epoxy) on the side of the brace to attach to the fuse and around the area of the phenolic tube that was cut to fit (center tube in this picture), where it will contact the brace and fuse. Assemble as shown and use some hard wood or bamboo chop sticks to help push the brace against the fuse. Use as many as necessary to get a tight fit.

EAM BOMBER 17 FUSE INSTRUCTIONS



The rear former is located just aft of the top hatch. The line indicates roughly where it is located.



Looking rearward the former should be installed like this. The servo tray and braces are included and should be glued to the former **BEFORE** installation.

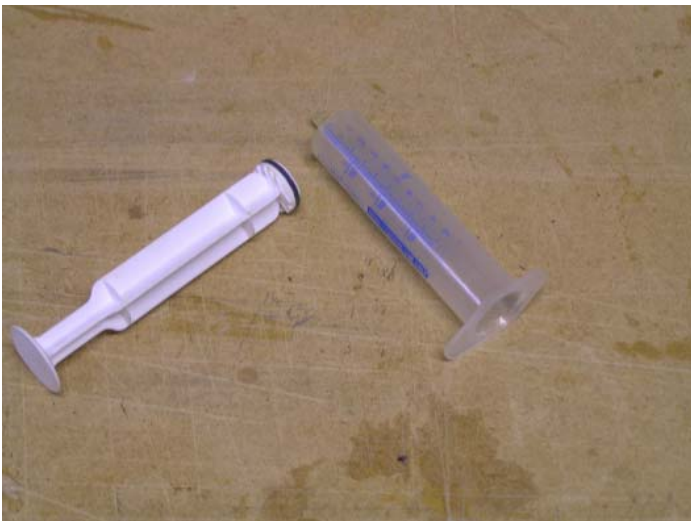

When working in a tight location I will use a child's medicine dispensing syringe. Set up your pieces and know how to get them in, work quickly.

EAM BOMBER 17 FUSE INSTRUCTIONS



Another view of the former, polyurethane glue will expand to fill the gaps and give a good strong joint.

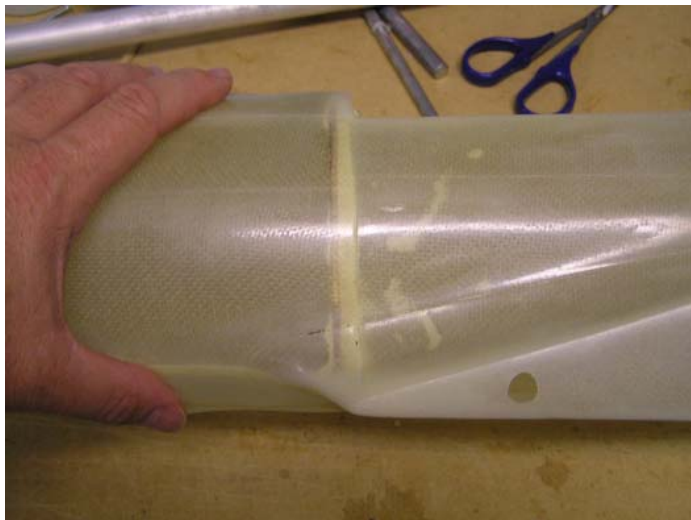

Rear former location.

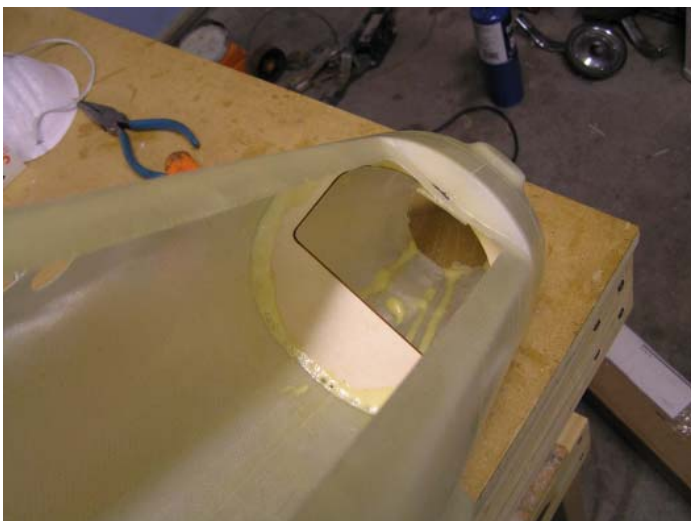

The front former is located just ahead of the top hatch. There are no brackets to be mounted to this, currently.

EAM BOMBER 17 FUSE INSTRUCTIONS

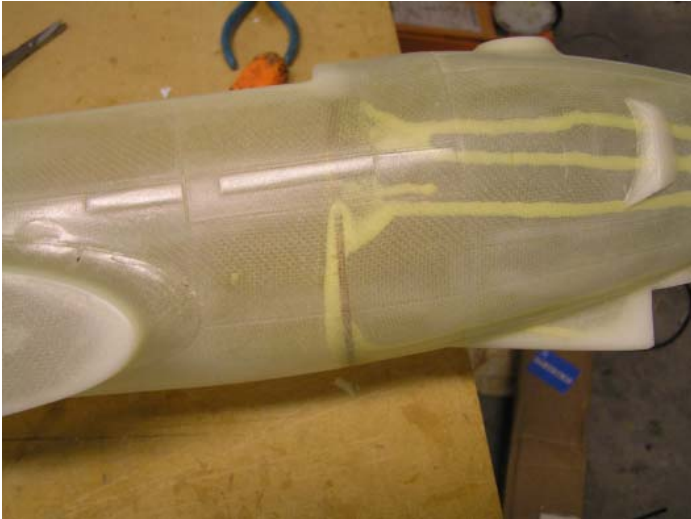

This shows the location of the front former. After applying the glue, wipe up the excess with a damp paper towel, so it doesn't run, like this!

EAM BOMBER 17 HORIZONTAL STABILIZER INSTRUCTIONS

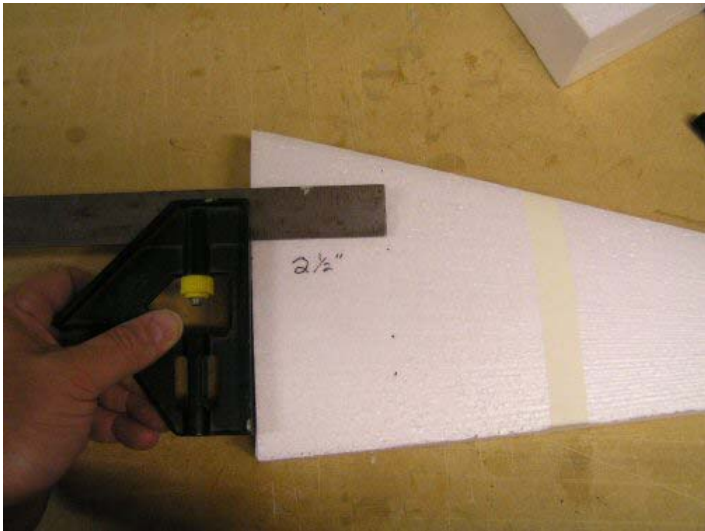

Mark a line, 2 1/2" from the root end of the foam. Then mark a line 1 1/4" from the trailing edge, this is your top point. Cut or route out a 1/8" slot from front to back, ending at the 1 1/4" stop line.

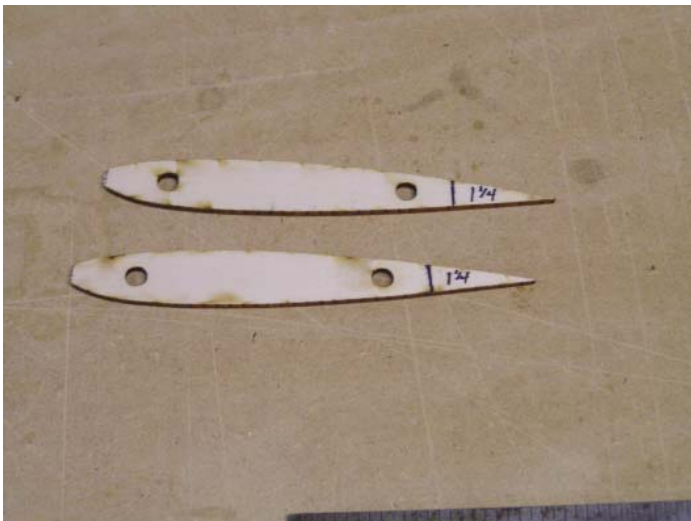
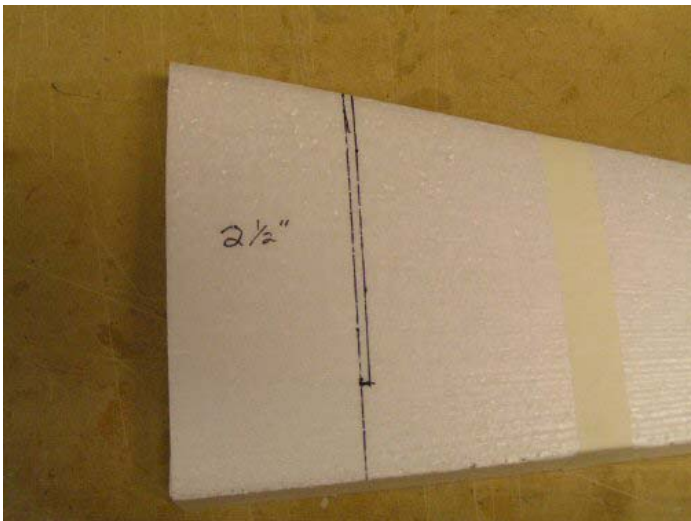

For this first revision, you will need to cut 1 1/4" off the rear of the of the sub rib. This will be corrected in the next update for the laser cut parts. If the sub ribs already appear cut, then you have the latest version.

EAM BOMBER 17 HORIZONTAL STABILIZER INSTRUCTIONS

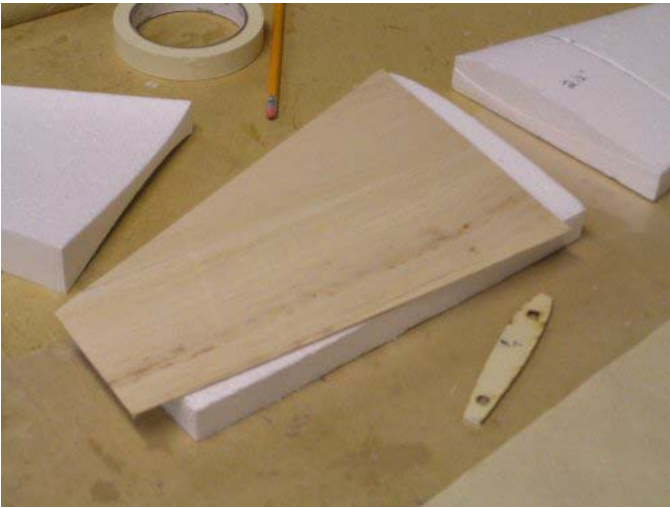

No use in showing how to make templates again. Refer to the wing instructions if a refresher course is needed. This is what the sheets should look like.

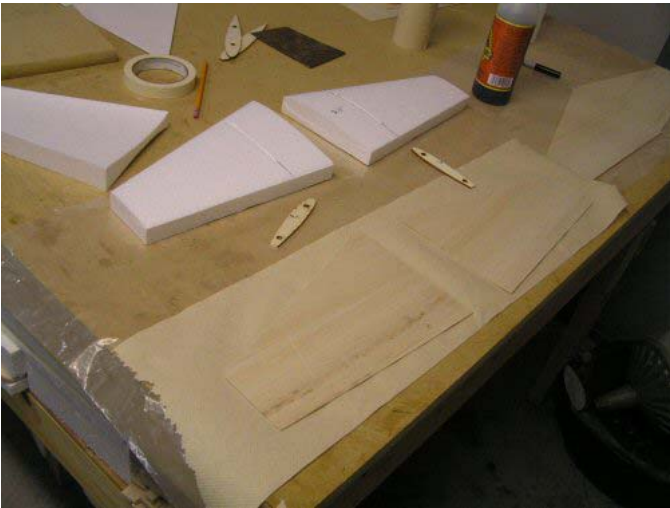

Set up to sheet the horizontal stabilizer. Put glue on sub rib and sheeting. Place sheeting on one side, drop sub rib in, then complete sheeting the horizontal stab, repeat for other side.



Place as much weight as possible, again the trick is to get everything lined up, it will shift as you add weight.

EAM BOMBER 17 HORIZONTAL STABILIZER INSTRUCTIONS



While the sheeting is drying, cut a 1/4" x 3/4" piece of balsa to 11" in length. Then rip the balsa with one end being = or > 9/16" and the other being = or > 3/8". Pre cut your tip piece using 1/2" x 2" balsa



Tape the leading edge on (remember to check the ends), sand the tip and root flush. Tape on the root wing cap. Leave the glue off the cap from the trailing edge up about



Tape the tip on and set aside.

EAM BOMBER 17 HORIZONTAL STABILIZER INSTRUCTIONS



Sand the stabilizer and tip using a block, always working with the grain of the sheeting. Mark the cut out for the elevator using a square as follows:

If no dimensions are present here, check the EAM web site for updated dimension and instructions.



The complete cut out will look like this. Cut a piece of $\frac{1}{4}$ " x $\frac{3}{4}$ " balsa to cap the elevator and the stabilizer portion. Glue and tape in place.



The $\frac{1}{4}$ " balsa will fill this gap when glued to each piece.

EAM BOMBER 17 WING ASSEMBLY

BUILD THE FUSE FIRST!

Wing step 1

Before cutting the slots in the wings for the ribs, make a template for the sheeting. Take a piece of poster or art board and tape it to the front edge of the wing, on the top side, then roll it over and trace around the wing. Add $\frac{3}{16}$ – $\frac{1}{4}$ inch on the trailing edge and $\frac{1}{8}$ inch on the tip of the wing (nothing on the root end) and make SURE you are wrapping it around the wing's topside as this will be the longest side.

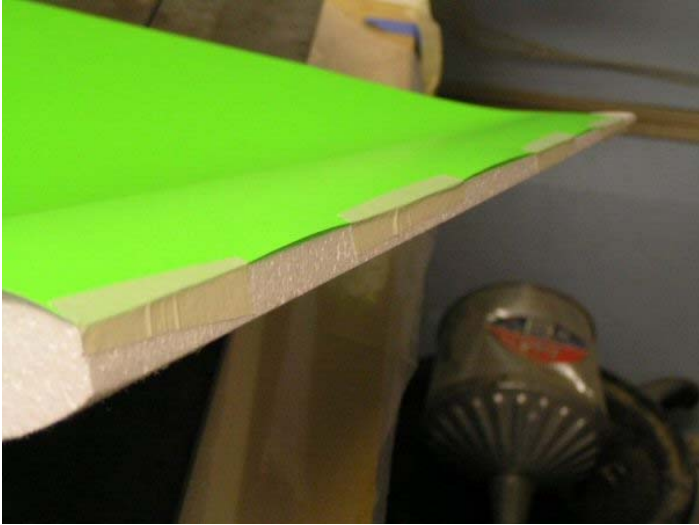

EAM BOMBER 17 WING ASSEMBLY

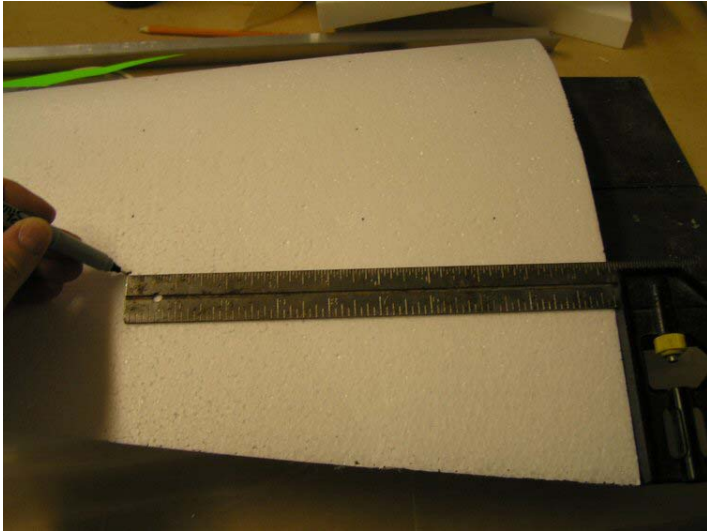

Mark the dimensions using a square. Mark dots from the leading edge back. Then connect using a scrap of poster or art board, or any other flexible and straight edge. The revised laser cut parts will only require slots to be cut for the two inner locations (closest to the root). You can tell which set you have by assembling your nacelles. If the outer nacelles are square at the rear, then you have the early 4 rib set. If the outer nacelles have a cut out to match the leading edge of the wing, then you do not need to cut the slots for the outer wing ribs.

The marking dimensions are as follows:

From Root	From leading edge for cut stop
2 1/4"	7 5/16"
5"	6 15/16"
9 3/4"	6 1/4" Not required for later revision laser cut parts.
12 1/2"	5 7/8" Not required for later revision laser cut parts.

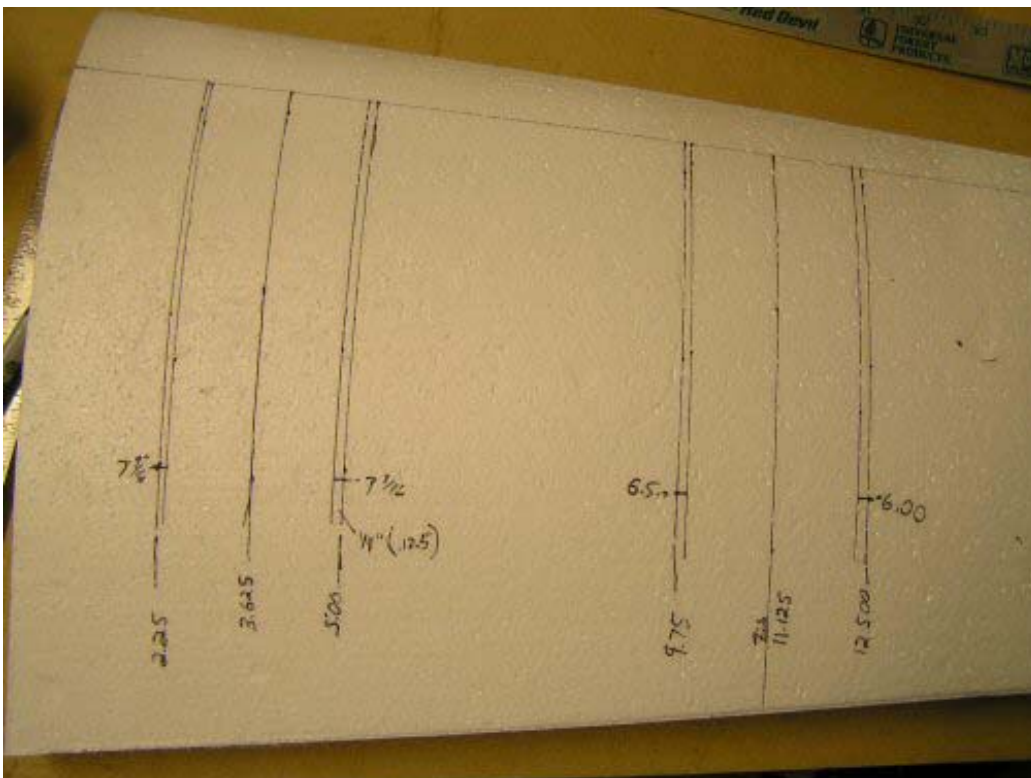

EAM BOMBER 17 WING ASSEMBLY

Also mark the motor centerlines:

3 5/8" Inner motor centerline (important later).

11 1/8" Outer motor centerline (again important later). Not require on later revision laser cut parts.

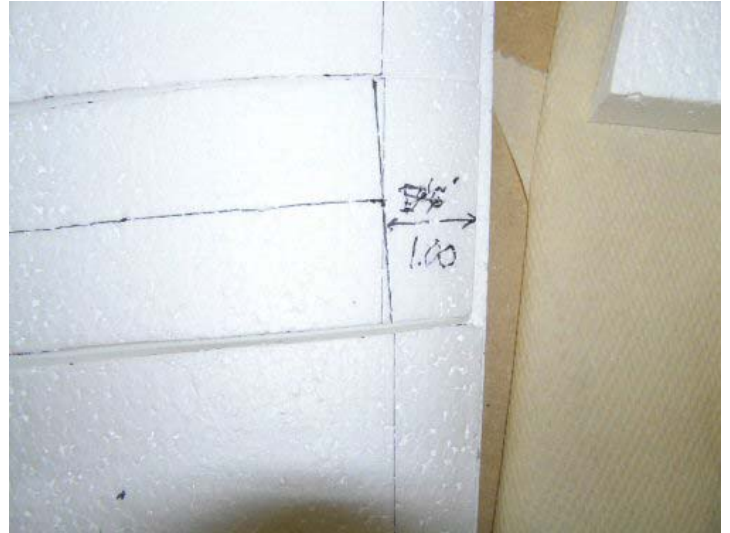
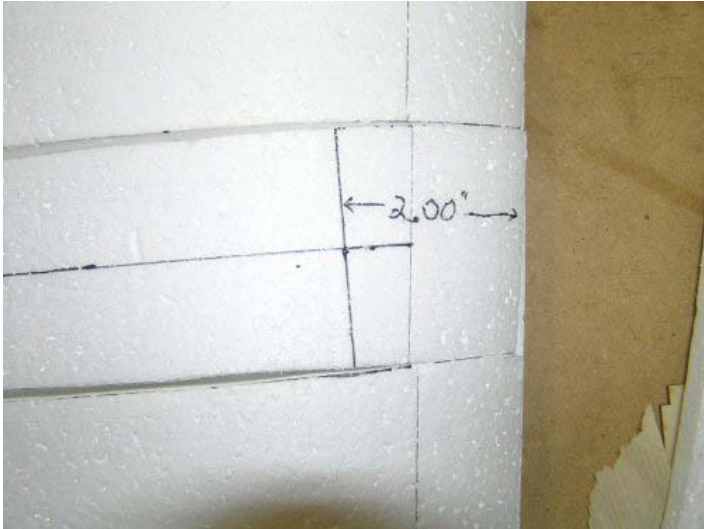

Measure back 2" from the leading edge down the inner motor centerline and draw a line perpendicular (at right angles to) the motor center line from the 2 1/4" line to the 5" line.

Now measure back 1" from the leading edge down the outer motor centerline and draw a perpendicular (at right angles to) the motor centerline.

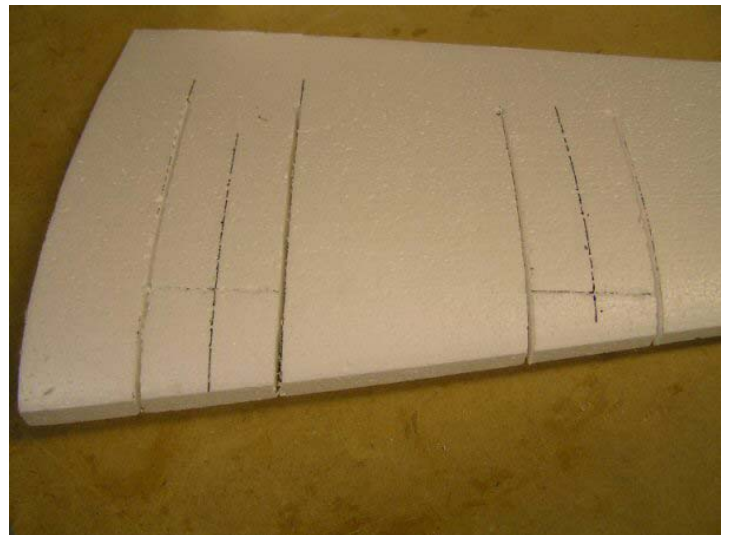

Route inside the lines marked, not counting the motor centerlines. Cut out the leading edge offset for the nacelle. This may need to be trimmed back further after the wing is sheeted, the adjustment is made when installing the nacelle, with the cowling installed.

EAM BOMBER 17 WING ASSEMBLY

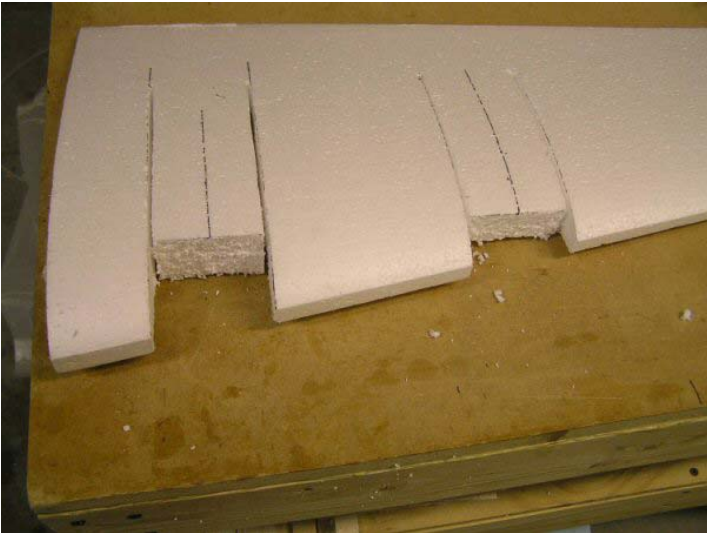

The cut outs will look as above. If you have the later version of the laser cut parts, there will be NO OUTER RIBS and therefore no outer cuts will be required.

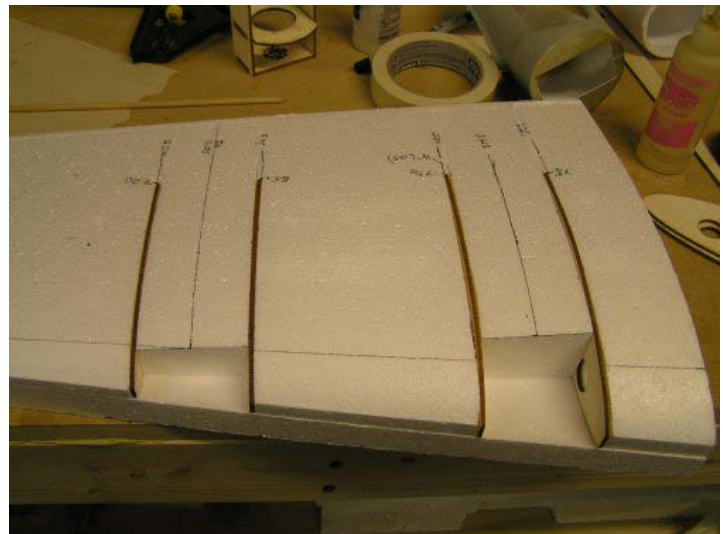
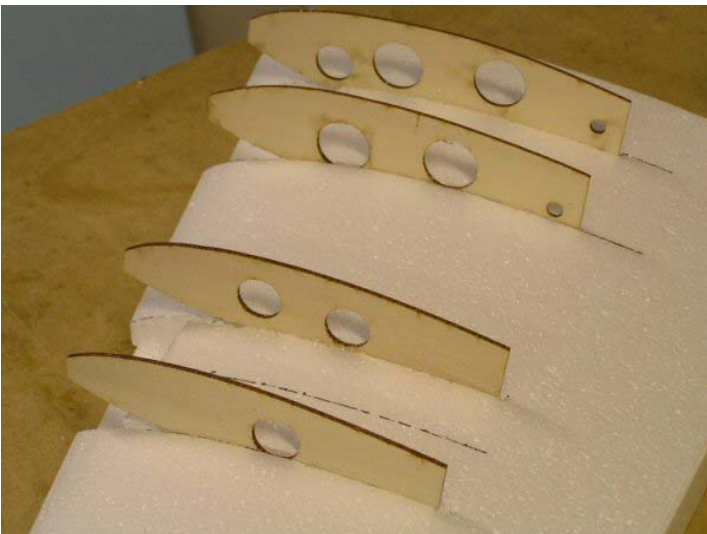

The ribs will fit in this order, when gluing, leave the glue off the exposed frontal area on the inside of the cut out. If you have an early kit, refer to the adendum at the end of the instructions. Some modification of the ribs is required.

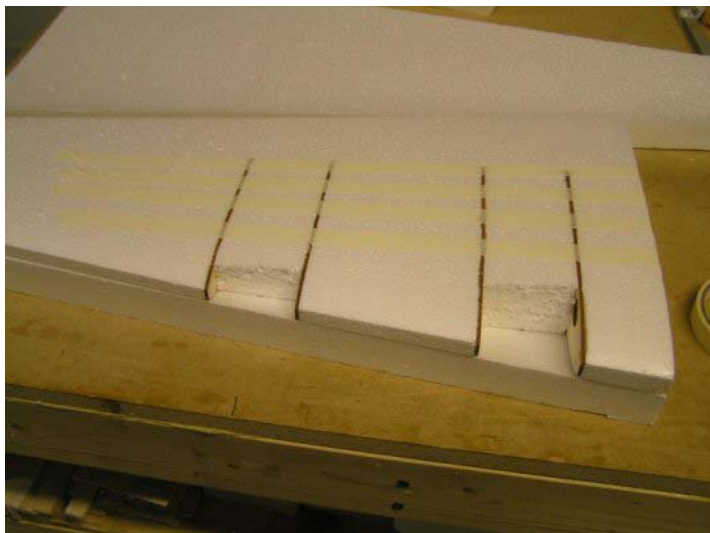

Insert ribs into core, place assembly in top shuck and tape the bottom side as shown. REMOVE RIBS.

EAM BOMBER 17 WING ASSEMBLY



Lay a piece of 1 - 4 mil poly plastic (drop cloth) on bottom shuck.

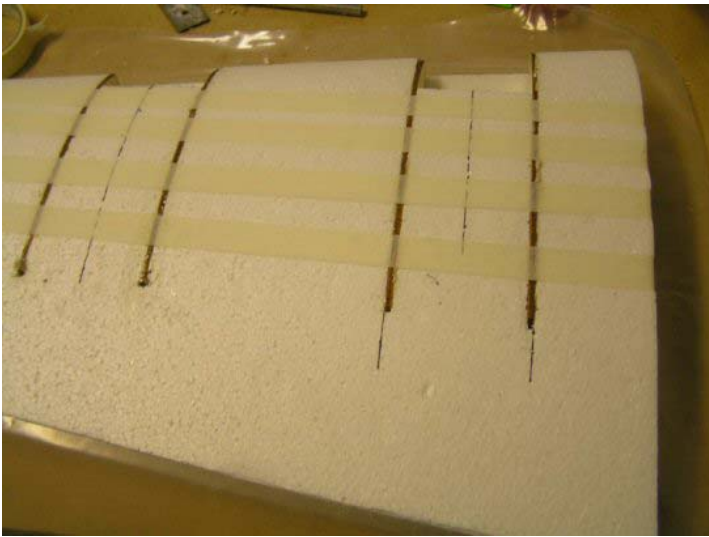

Apply a thin layer of PU glue or epoxy to ribs and insert into wing. Tape top of wing core as shown.

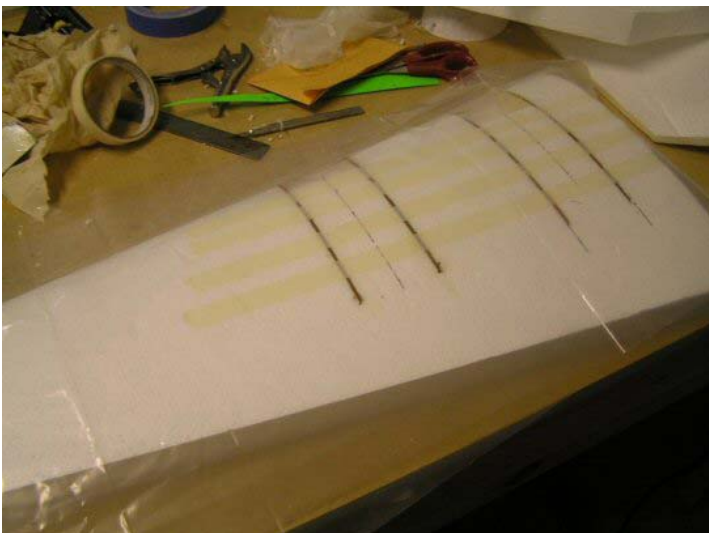

Lay another piece of 1-4 mil poly on top of wing.

EAM BOMBER 17 WING ASSEMBLY



Place top shuck over assembly and weight down. If you use the PU glue, allow it to dry for at least 4 hours.

Trace the sheeting outline from the template made earlier. Make sure the grain is parrallel to the trailing edge.

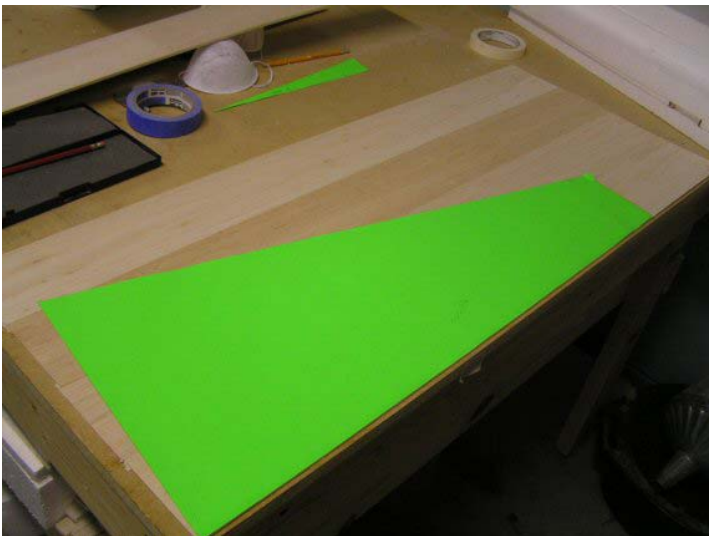

EAM BOMBER 17 WING ASSEMBLY



This is what one set should look like, the second set should be a mirror copy. This creates your top and bottom layers.



What your two sets of sheeting should look like. From here I cut out the sheets using a NEW #11 blade and a 1" aluminum angle on top of sheet rock.



EAM BOMBER 17 WING ASSEMBLY

Set the wing in the top shuck, bottom side up. Spray BOTH SIDES of the sheeting with a light mist of water. Spread the PU glue on the tape free side, of the bottom wing sheeting. It will take a small spreader of some sort and a goodly amount of glue to cover the sheeting. Lay the sheeting on the foam and tape the leading edge and root edge to the foam. Repeat the process for the opposite side. Place as much weight as possible on the wing.

Some special notes.

- 1) Tape the sheeting in place well before placing the weight on it. The poly plastic can make it difficult to get the cores to stay put. If this is the case wipe all the excess glue off the outside of the wing and try it without the poly. The worst case is you have to sand a bunch of foam off the wing. The preferred method is vacuum bagging.
- 2) Don't be stingy with the glue. Excess sands easily, but it is a real pain to try and re glue sheeting together. Most of these problems are easily avoided by vacuum bagging.



The sheeting has been applied and the wing is placed in the bottom shuck. Tape the sheeting to the leading edge and the root, but do not over lap the top side of the wing with the tape.

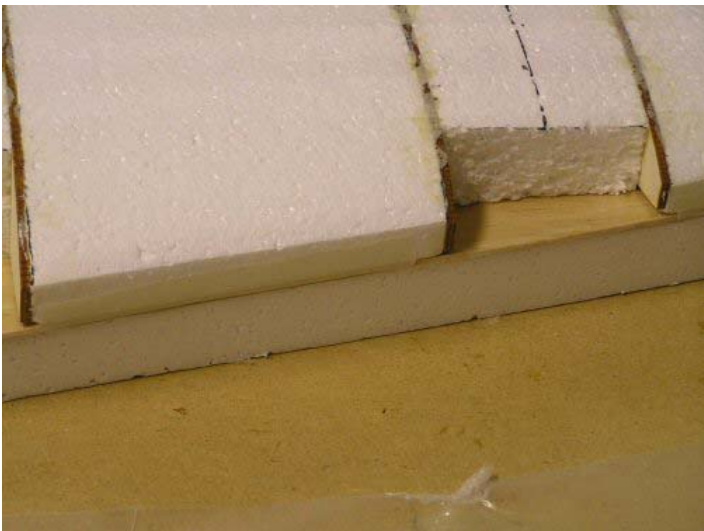

The tape should be placed on like this, holding the leading edge of the sheeting even with the leading edge of the wing. A slight overlap is O.K. and is preferable to not matching the leading edge.

EAM BOMBER 17 WING ASSEMBLY



The top wing sheet has been coated with PU glue and taped into place. Now place some poly drop cloth on the top and bottom of the wing, between the wing and the shuck, to prevent any glue that may have gotten on the outside of the wing from sticking too.



Place a board and as much additional weight as possible on top of the board. The wing will shift in the shucks, due to the plastic, but you can simply push it back with the weights in place.

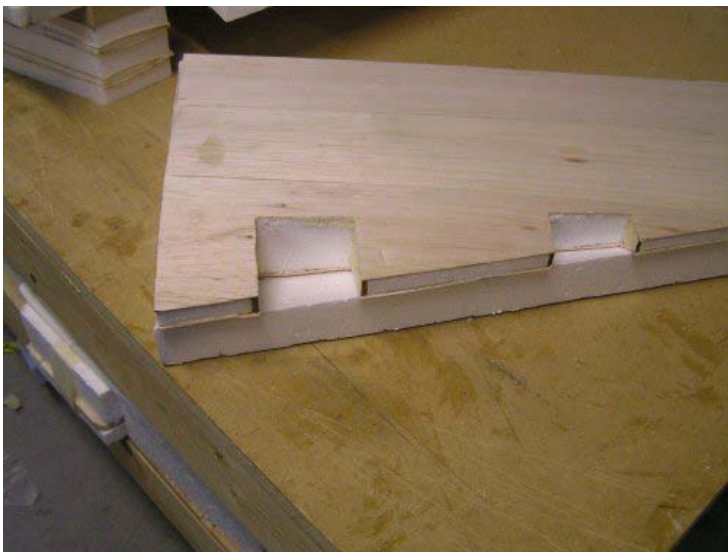

Cut out the wing nacelle areas. You can rough cut with a coping saw, but leave at least 1/8" to clean up with a hobby knife or sanding block.

EAM BOMBER 17 WING ASSEMBLY

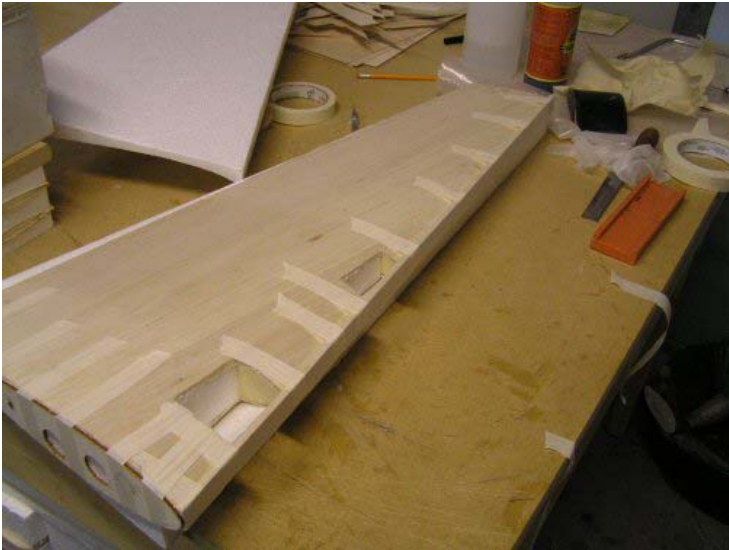

Sand down the sheeting, on the leading edge, even with the foam. Glue a 1/4" x 3/4" x 36" or larger balsa stick in place on the leading edge of the wing. Tape well. Trim the ends with a razor saw or hobby knife, sand flush.



Attach the wing root with the leading edge even with the front of the balsa leading edge. Tape well. Time for...a refreshing beverage and...



Cut the sheeting and sand even with the foam core.

EAM BOMBER 17 WING ASSEMBLY



Cut the wing tip, sand the leading edge flush with the end of the wing and tape on.



Sand the wing to shape, leading edge, tip any glue through the seams, etc. Leave the leading edge across the cut outs for strength and to prevent messing up the sheeting when sanding.

When sanding the wing leading edge, use a sanding block and 100 to 120 grit sand paper. Sand in the direction of the grain of the sheeting, working from the inside of the wing (root) toward the tip. The initial goal is to get the leading edge shaped to the same angle as the sheeting. Do this to both sides, leaving a flat front edge. Then begin working a little from both sides and rolling the block over the front edge. Work for a consistent airfoil shape. DO NOT press hard when sanding, let the sandpaper do the work. A belt sander can be used to carefully rough the leading edge first.



The aileron begins $\frac{1}{4}$ " from where the tip was glued on to the sheeted foam. Measure $\frac{1}{4}$ " out towards the end of the wing, then $13 \frac{1}{4}$ " toward the root. Using a square mark lines at each end 2" in and connect.

Cut the aileron ends with a coping saw or a jig saw, then using an aluminum angle and hobby knife, cut the long cut in several passes, connecting the cuts made with the coping saw.

EAM BOMBER 17 WING ASSEMBLY



Cut a piece of $\frac{1}{4}$ " x $\frac{3}{4}$ " to $13 \frac{1}{4}$ " in length and using the poly glue or epoxy, attach to the front of the aileron cut out. This will be the hinge mounting location. Cut a small piece of 2mm or $\frac{1}{16}$ " – $\frac{3}{32}$ " thick large enough to cover the inside of the cut out. It should be approximately $2 \frac{1}{4}$ " x 1"



After cutting out the aileron, cut the leading edge from the nacelle cut outs and sand smooth. This is an early kit, the outside cut out is not necessary on later kits. You will only be required to cut away the leading edge where the nacelle mounts.

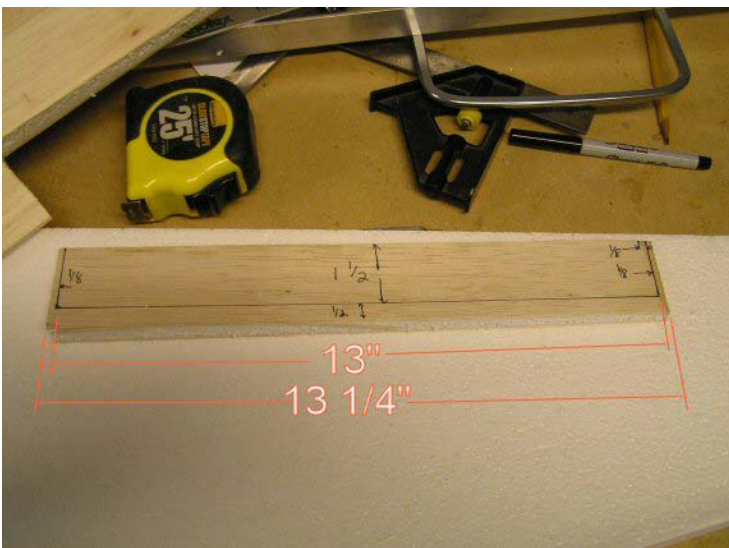

Measure in $\frac{1}{8}$ " from each end of the aileron, then using a square, draw a line $1 \frac{1}{2}$ " long from the trailing edges. Connect these lines as in the picture. Cut away the outside of the aileron.

EAM BOMBER 17 WING ASSEMBLY



Next cut a 13" long piece of $\frac{1}{4}$ " x $\frac{3}{4}$ " and 2 pieces of 2mm or $\frac{1}{16}$ " – $\frac{3}{32}$ " thick balsa, large enough to cover the ends of the aileron. They should be approximately $2\frac{1}{4}$ " x 1". Glue and tape as shown.

After it has dried, sand smooth using a sanding block and following the grain of the sheeting. The bevel on the front cap strip, will depend on the type of hinge you prefer to use.

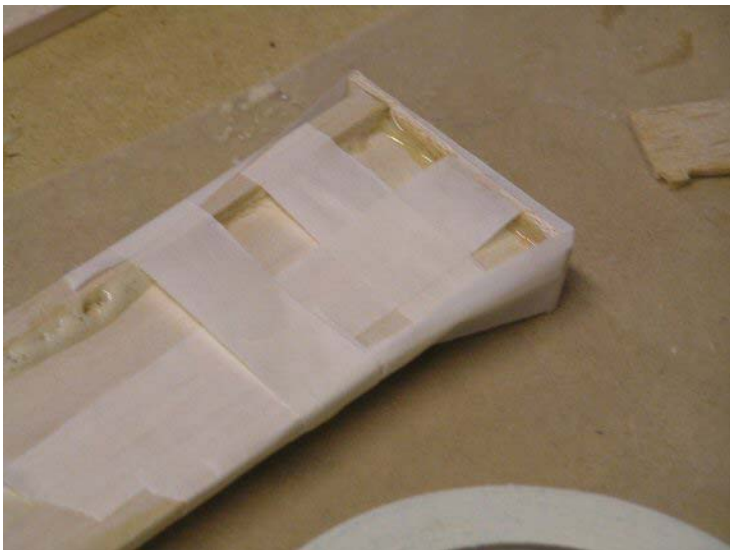

EAM BOMBER 17 WING ASSEMBLY

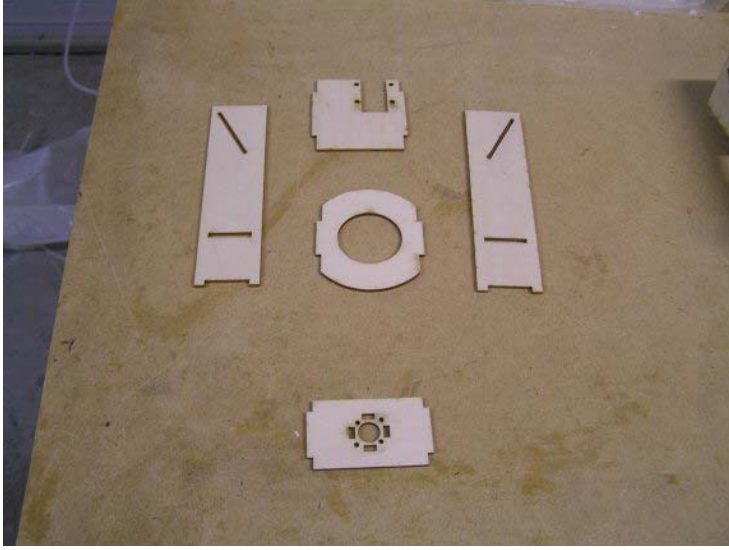

Pictures of the inner nacelle pieces and fully assembled with retracts. Be careful about the assembly of the landing gear mount, everything else is symmetrical. Make sure you have a "left" and "right" side. The retracts are biased to the inside, as the tire is on the outside. Always test fit BEFORE gluing together. You can use CA, epoxy or PU glue.

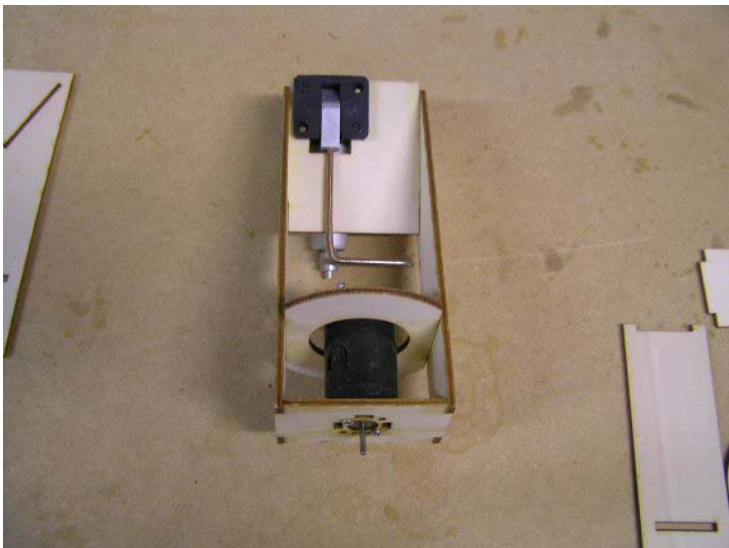
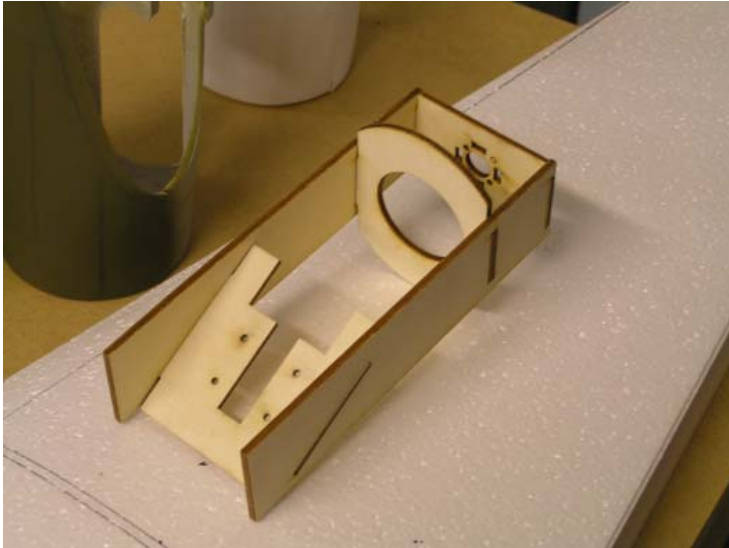

EAM BOMBER 17 WING ASSEMBLY

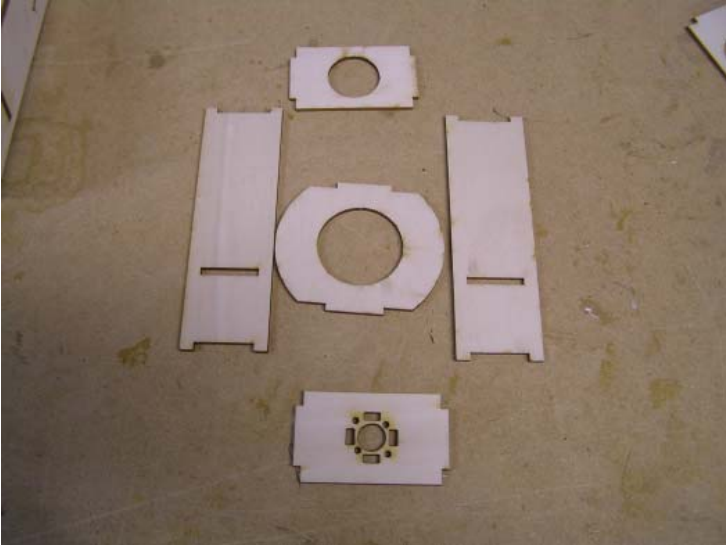

Outer nacelle pieces.

In later versions of the kit the outer nacelle wraps around the wing at the leading edge.

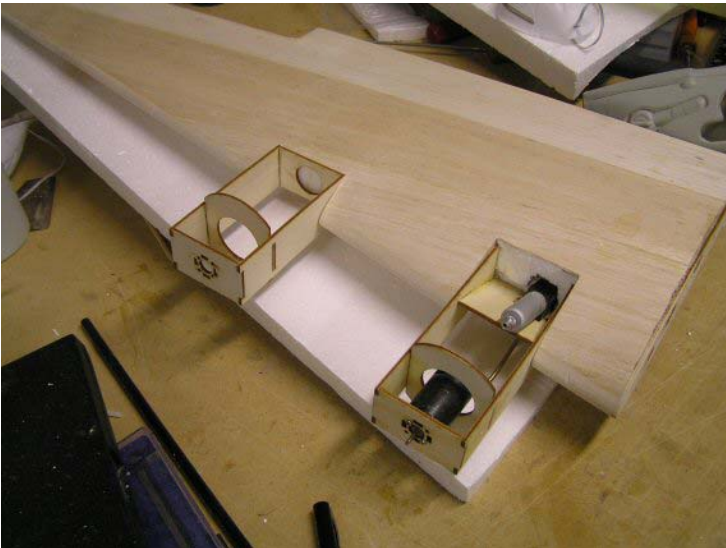

When fitting the nacelles, place the assembled cowling over the nacelle and cut away at the wing until the cowling touches the wing leading edge. Make sure you have the cowling on correctly. This is a view of the top of the wing with the nacelles placed, but not glued. The motors should be in line with the center of the wing.

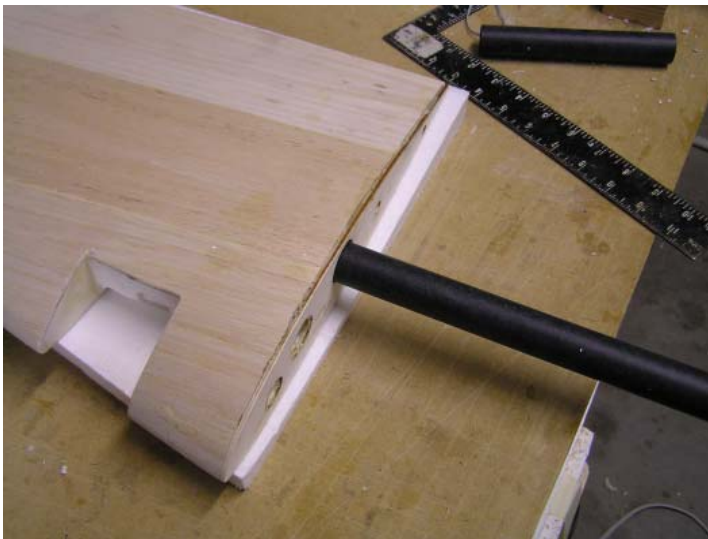

There are 2 methods for removing the unwanted foam on the inside of the wing.

- 1) Using a 1/4" or larger rod, driven into a wooden handle, heat the rod and melt the foam to allow the sleeve to pass through the outer two sub ribs.
- 2) Using a tube that will fit inside the wing holes (multiple size tubes can be used, cut away the foam to allow the sleeve to pass through the outer two sub ribs).

Be certain to also cut back the foam at the location for the carbon fiber tube.

EAM BOMBER 17 WING ASSEMBLY



Insert the tube and mark the where it stops with masking tape.



Remove the tube and check that it extends far enough into the wing to clear both outer sub ribs. Cut the sleeve just outside of this mark, test fit and sand so the sleeve does not protrude beyond the wing cap root.



Next install the aluminum and 7mm carbon fiber tubes.

EAM BOMBER 17 WING ASSEMBLY

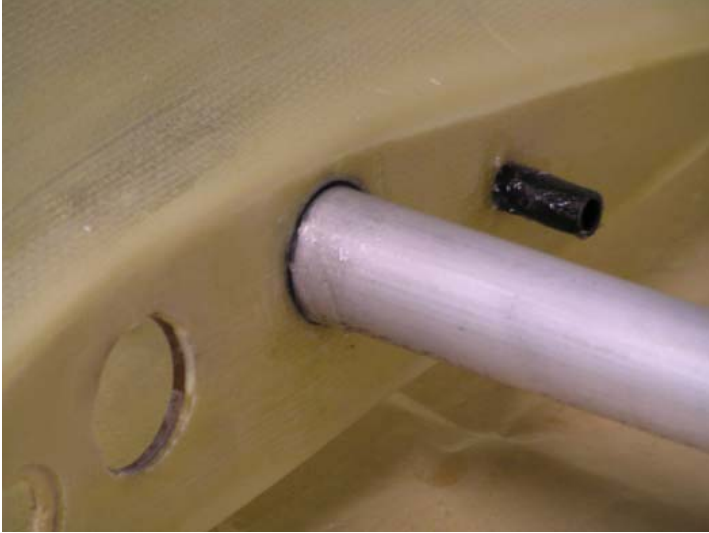

Add Petroleum jelly at the wing root location.

Cut a piece of poly plastic to fit over this area, allowing the tubes to protrude.



Put the phenolic sleeve on the aluminum tube, cover the outer end with masking tape and place a small hole in the tape. Cover the sleeve with polyurethane glue and slide the wing over the sleeve. Line the wing up with the fuse and tape and prop as necessary. Repeat immediately for the other side.



Prop both wings up so the tips are 3" above the surface of the table. Adjust as necessary to ensure the wing roots are flush against the fuse.

EAM BOMBER 17 WING ASSEMBLY



Should look like this when properly braced.

EAM BOMBER 17 WING ASSEMBLY

ADDENDUM

Due to a miss interpretation by me of the cad data, the wing sub ribs are slightly to long. Removed the dimensioned amount from the leading edge of the rib and from the total routed length in the foam. The leading edge of the sub ribs should still be placed at the leading edge of the wing. match the top of the rib to the top of the wing and sand the bottom fluse with the foam. Then proceed with sheeting.

REMOVE THE AMOUNT SPECIFIED BELOW PER MATCHING RIB, PLACE RIB AT FRONT OF WING, SAND TO WING SHAPE.

